

INSTRUCTION MANUAL



Litton Cutter S
Litton Cutter S

Components

- Main body
- Handle (cutter)
- Accessories

01
01
01

Methods of use

- How to use the product
- Status explanation
- How to charge
- Checklist before use and precautions

02
04
05
05

Product management

- Replacement of blade and replacement of blade fixture
- About blade and blade fixture

06
07

Safety cautions

- Warnings and cautions

08

Customer service

- Compensation for damage
- Product and battery standards

10
10

Self-diagnosis

- Before requesting repair

11

About us

- What materials do you want to our?
- Crowdfunding results
- Certifications / Patents
- Featured On

12
12
13
13

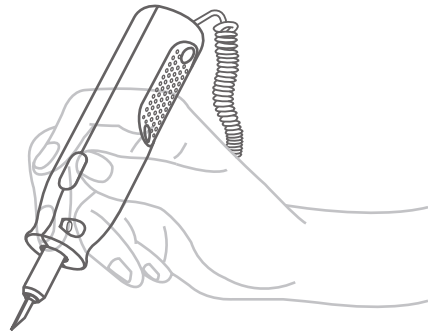

Components

• Main body

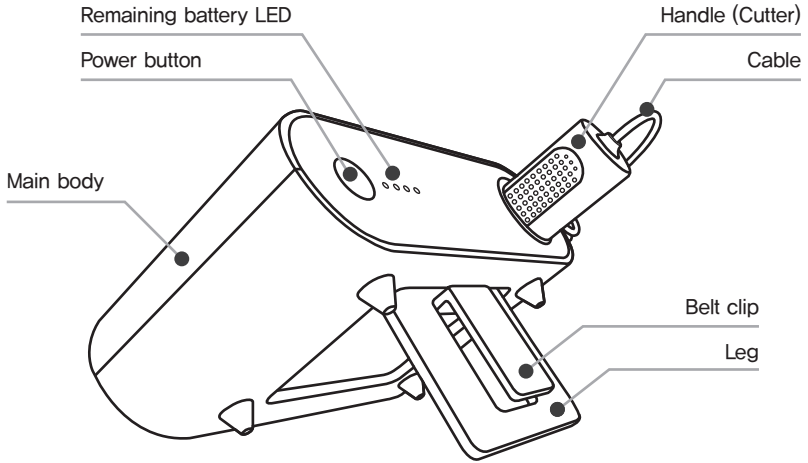

* The battery-pack is built-in.

• Handle (Cutter)

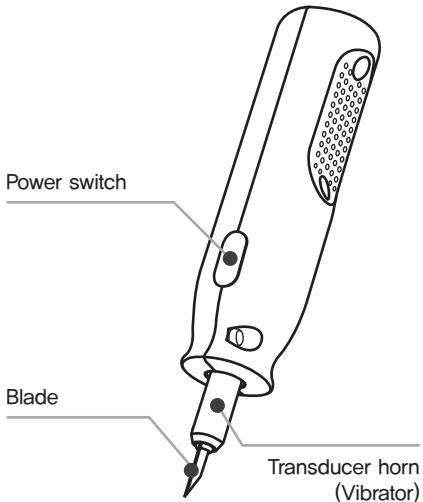

• Accessories

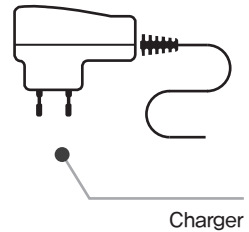

* Check for the following components.



How to use the product



01

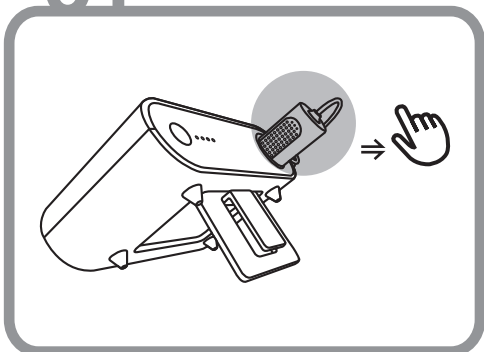

02

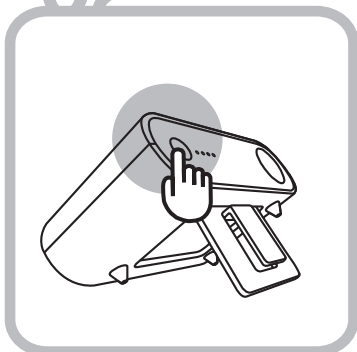

03

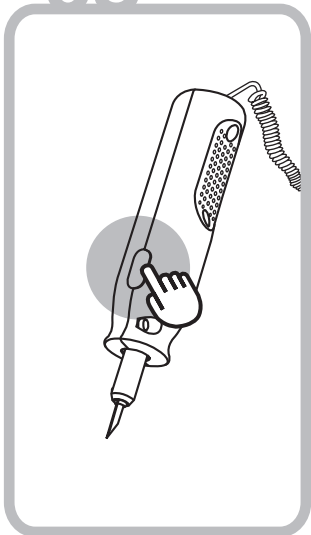

04

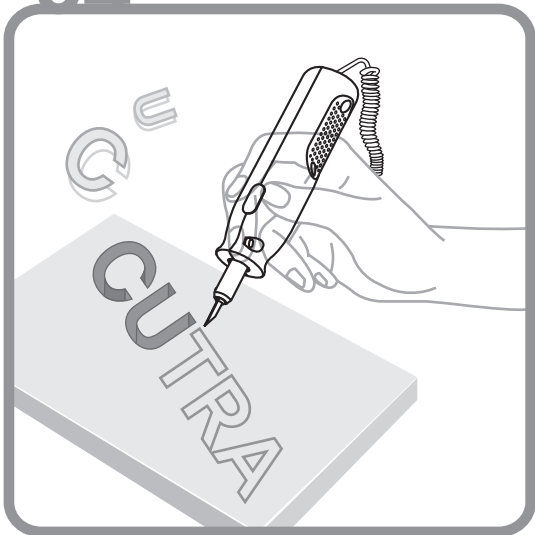

01

Pull the handle out inside the main body.

02

Press the power button of the main body for 1 to 2 seconds to turn the LED on the face panel on. This turns the product into stand-by state.

(another push will turn the power button off.)

* The LED (green) on the handle is off.

03

At stand-by state, press the power button on the handle. This will cause 40,000 vibrations per second. The cutter only operates while being pressed.

* The LED (green) on the handle is on.

04

When used for more than 10 minutes, the product stops operating and goes into stand-by state.

* The LED (green) on the handle is off under stand-by state. The inner temperature of the handle gets higher while being used, turning into high temperature stationary state.

* The LED button of the handle does not turn on in high temperature stationary state.

* The stand-by state extends based on the handle power button.

* When the main body is on, the vibrating part continually creates sound waves so the product must be turned off when not in use. When putting the handle back into the main body, be sure to center the working button. After using the product, be sure to turn the power off and put the handle in the main body.

Status explanation

○ Stand-by

The LED turns green when the main body is turned on.

The remaining battery can be checked on the LED of face panel.

* The LED(green) on the handle is off.

* The product turns off automatically after a beep when not used for more than 10 minutes in the stand-by status.

○ Up and Running

Vibrations on (pressing the handle button)

* The LED(green) on the handle is on.

○ High temperature stationary state

The product enters high temperature status after being used for 10 minutes.

The protective function turns the product into stand-by when in high temperature.

* When the temperature drops to a certain level, the LED(green) turns on.

○ Stand-by after buzzer sound

The continuous production of 40,000 vibrations per second generates high temperature vibration, and protective function is activated as the circuit is overload.

* The power button on the switch cannot be operated.

* The LED(green) button does not turn on.

* Loose setscrew of the blade or overload on the blade produces such situation.

* This does not turn into normal operation status by its own. Turn the power off and tighten the setscrew before restarting the device.

How to Charge

* Charge the product on the following occasions.

- Before using for the first time.
- Unused for a long period.

* Precautions when charging the device

- Use the domestic power code only.
- The product is fully charged in 2 hours.
- Keep a temperature of 5°C~40°C to charge.

Checklist before Use and Precautions

* Checklist before Use

- Check if the device is charged.
- The cutting ability may vary depending on the state of charge.
For maximum performance, please check whether the device is fully charged.
- **When using the device, we recommend you to use it with the charger plugged in for maximum performance.**
- Fix the product when carried around the waist.
- Install the blade correctly on the handle.
- Tighten the setscrew for safety reasons.

* Precautions

- Ultrasonic wave cutter cuts better than the normal cutter, so be careful.
- Wear necessary equipment such as safety glasses.
- Wear safety gloves before using the product at all costs.
- Wear adequate clothes for use.
- Depending on what is being cut, the cutting work can generate noxious gas.
Wear protective masks and ventilate the area.
- Keep the workplace clean and lights bright.
- Turn the main power button off when not using the handle and keep the handle in the main body. When putting the handle back into the main body, be sure to center the working button.
- Do not turn the product on when the handle is inside the main body.
- Fix the work being handled.
- Metal and glass cannot be cut by this product. Be aware of this.

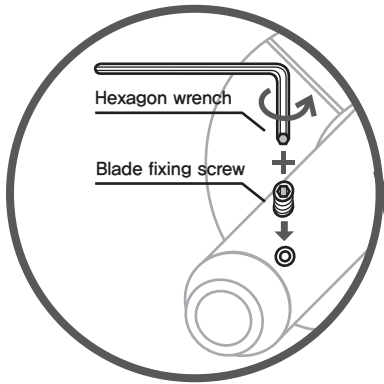

⚠ Attention

- Be careful when using the blade.
- The 40,000 vibrations per second rises the temperature due to friction and make the product very hot, including the blade, blade fixture, and setscrew. Be careful to not get burns.
- If you feel like it doesn't cut well or the power doesn't get turned on, try resetting the device.

* Replacement of blade and replacement of blade fixture

1. Change the blade when the product is turned off and tighten the setscrew.
2. Be sure to reset the device after changing the blade.
3. Follow these steps to reset the device. After tightening the setscrew, press the button on the handle and also the button on the main body for 5 seconds. The cutter assembly is automatically detected and the sensor beeps with LED light on for 1.5 seconds then the product turns off. If it shows 4 LED lights after the product turns off, it means that it has been successfully reset. If it doesn't show all 4 LED lights, tighten the setscrew until there are 4 LED lights on.
4. Once the setscrew is fixed, turn the power of the main body on and press the handle switch on to check that the product works correctly.

* If it still doesn't work after resetting, please try cleaning the inside of transducer horn by following the steps below.

1. Turn the main power off.
2. Take off the blade and the blade fixture. Then clean the inside of transducer horn with q tips.
3. Tighten back the setscrew using a hexagon wrench.

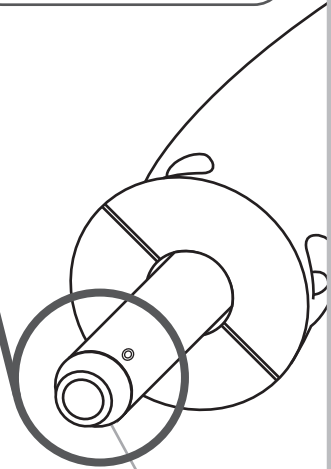

+ Transducer horn



+ Blade fixture



+ Blade

* About blade and blade fixture

1. In order to transmit the ultrasonic waves, fix the product with the adequate blade and blade fixture.
* Make sure that the blade and its fixture are correctly fixed.
2. The stain on the blade or on its fixture can cause heat, noise, and damage of the product.
* Make sure the product is stainless, and change if there are any stain on the blade or its fixture.

○ When changing the blades

Insert the dead end of the blade that will be changed into the inside of the blade fixture. Line up the holes of blade setscrew and the blade fixture.

○ When changing blade fixture

Line up the holes of the blade setscrew and the new blade fixture.



Cautions

- Be careful with the dead end of blade and the direction of blade.
- Use the designated blades only.
- When other than designated blades are used, the product might not operate correctly and this can cause breakdown or fall out of the blades.
- When the blade is not correctly adjusted, a buzzer beeps and the handle power button does not operate.

○ Lastly

Make sure that the blade and its fixture is correctly set, and tighten the setscrew with a hexagonal wrench.



Cautions

- Tighten the setscrew of blade.
- When the setscrew is not correctly adjusted, the blade can pop out and this may cause accidents and cause of breakdown.
- Change the hexagonal wrench when worn down.
- Ask for the manufacturer's help when the setscrew does not fall out.
- When the blade has been changed while the vibrator produces heat, the setscrew can loosen when the temperature goes down. Make sure that the setscrew is correctly fixed before using the product.

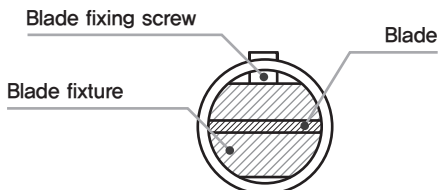

Safety cautions



Warning

If the instructions are not correctly followed, death or serious injury can occur.



Cautions

If the instructions are not correctly followed, physical damage or property damage can occur.



Keep away from water.



Never decompose the product.



Be careful to high temperature.

Warnings

- Do not bend, pull, twist, or put heavy objects on the cable.
- Do not touch the product with wet hands.
- Do not expose the product into any type of liquid.
- Immediately stop using the product when in touch with water.
- Do not use the product when the cable or AC adapter has been damaged.
- Do not use the product to cut inflammable objects such as oil paper.
- Do not under any circumstance touch the blade while being operated.
- Do not look into the blade when used. Do not point the blade to any person.
- Do not use the product for anything with electric current on.
- Grab the plug in order to pull out the charger.
- Keep the product away from children.
- Do not give strong physical impact on the product.
- Do not remodel or decompose the product. Never repair, remodel, or decompose it.
- Do not insert any metals in the opening crack.
- Do not incinerate the product.
- Do not use the product to cut metals or glass.
- Do not touch the blade after using, since the high temperature can cause burns.

Warnings

- **Do not use the product in the following places.**
 - Places with high temperature or inflammable objects.
 - Places with dust and generating corrosive gas.
 - Places with high vibrations and impacts.
 - Wet and humid places.
- **Be careful to not to drop the blade while moving the product.**
- **Depending on what type of object is cut, it can cause substance or gas that affect the human body. Check before using.**

Cautions

- Do not put spray on the main body, cutter, and charger.
This may cause deterioration or breakdown of the plastic or paint.
- Immediately turn the power off for any smell or smoke caused.
- Turn the power off when changing blades or working on maintenance.
- Do not use the device on anything else than what it is meant for.
- Fix the blade correctly before using.
- Use the designated blade only.
Other types of blades can cause severe problems as they may not operate correctly and be detached.
- Do not get rid of the worn-out blade as regular waste,
and follow the local government rules in order to throw it away.
- Do not use the product near precise control, electric apparatus, and vibrating equipment. This can cause severe problems to the device.
- Grab the cutter in the correct way.
- Do not exert excessive power to the dead end of the blade.
- Turn the power off and put the handle in the main body when not in use.

Compensation for damage

- Cutra Co., Ltd. guarantees its products for a period of one year since the date of purchase. If any defect due to faulty materials and workmanship occur within this one year guarantee period, Cutra Co., Ltd. will repair or replace the product at its expense.
- Cutra Co., Ltd. will only pay for repair or replacement if convincing proof is provided, for instance by means of a receipt, that the day on which service is claimed is within the guarantee period.
- The guarantee is not valid if a defect is due to damage caused by incorrect use, poor maintenance or if alterations or repairs have been carried out by persons not authorized by Cutra Co., Ltd.
- Any attempt to disassemble the product will void the guarantee.
- For the device to be used correctly, the user should strictly adhere to all instructions included in the user manual and should abstain from any actions or uses that are described as undesired or which are warned against in the user manual.
- Do not use the device if the cable is damaged or has visible cracks. If the cable is damaged, you must have it replaced by Cutra Co., Ltd., or a service center authorized by Cutra Co., Ltd. in order to avoid a hazard.
- Please note that our guarantee does not cover any consumables or accessories such as blades, batteries, and a recharger.
- Please be aware that the buyer is responsible for round trip shipping costs regardless of any reason.

Product and battery standards

Model Number	WC40000F25W	Type	Lithium Ion battery
Oscillation Frequency	40 kHz	Volume	2600 mAh
Body Dimensions	175 x 102 x 62 mm	Voltage	11.1 V
Handle Dimensions	∅ 28 x 104 mm	Normal transfer capability	15 V ± 0.05
Body Weight	Approx. 670 g	Maximum charging voltage	12.6 V ± 0.05
Handle Weight	Approx. 85 g	Standard charging current	520 mAh
Max. Power Consumption	30W	Maximum charging current	2600 mAh
Charger	INPUT: AC100~240V, 50/60Hz, 0.6A MAX	Weight	140 g
Ambient Condition	5 ~ 35 °C	Temperature	AI Charge 0 °C ~ 45 °C AI Discharge -20 °C ~ 60 °C
		Storage temperature	-5 ~ 35 °C
		Usage period	300 cycles

Self-diagnosis

Before requesting repair

When the product does not function, check the following before requesting any type of repair.

Symptoms	Checklist	Solutions
The power button won't turn on.	Is there any remaining battery?	Connect the charger to the back side of the main body.
The handle switch won't work.	Is the power button off?	Turn the power button on.
	Was the handle switch pressed for a moment only?	Continuously press the handle switch.
	Is the LED light on the handle off?	After 10 minutes of use the product automatically turns to stand-by state, and press the handle switch within 10 seconds for use. Circuit protection status. Turn the power off and tighten the screw before restarting.
The handle makes noise and it does not cut well.	Is the blade fixed?	Fix the blade and setscrew tight.
	Is the blade bent or broken?	Clean the inner parts of blade, blade fixture, setscrew, and the dead end of the vibrator.
	Is the blade setscrew contaminated or has its shape changed?	
	Is there any foreign substance on the blade or at the dead end of the vibrator?	
	Is a designated blade being used?	
The handle gets hot.	Was the product used for a long time?	After 10 minutes of use the product automatically turns to stand-by state, and press the handle switch within 10 seconds for use. The device may get hot sooner and turns to stand-by state after using less than 10 minutes if you try cutting hard or thick materials.
	Is too much pressure being held on the blade?	The product is a light ultrasonic wave cutter. Do not exert too much power and hold it correctly.
	Is the blade and setscrew correctly fixed?	If the blade is not correctly fixed, the vibration temperature can affect negatively on the product's life cycle.
	Is the blade, setscrew, or the dead end of the vibrator contaminated?	Clean the inner parts of blade, blade fixture, setscrew, and the dead end of the vibrator.
The ultrasonic wave vibrations stopped.	Is there too much pressure held on the switch button?	The blade is stuck. Relax before using it again.
	Does the LED light turn on following the buzzer sound?	It's a stationary state due to the high temperature. Wait until the handle temperature cools down. Protective function is activated. Turn the power button off and check the setscrew before restarting.

What materials do you want to cut? _____



PLASTIC



PVC FOAM BOARD

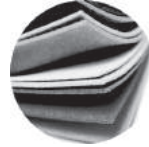

FELT



PAPERBOARD



RUBBER



LEATHER

Crowdfunding results _____

**KICKSTARTER**

Makuake

&



INDIEGOGO

- Funding Goal : \$ 50,000
- Total Funding Raised : \$ 250,553
- Total Backers : 873
- Reached Funding Goal in 5 days
- 46 Countries

Certifications / Patents



Certificate of Patent



Certificate of Trademark Registration



A patent application for its technology



'Gold Prize'
44th Salon International
Des Inventions Geneve 2016



'Gold Prize'
Silicon Valley International
Invention Festival 2018



'Gold Prize'
Seoul International
Invention Fair 2016

Featured On





CUTRA

CUTRA CO.,LTD.

Address : Inha UNIV., DreamCenter1, no.310, Inha-ro 100,
Michuhol-gu, Incheon, Republic of Korea 22212

FAX : +82-0504-475-0927

Website : wondercutter.com

Email : wondercutter@naver.com

Skype/Linkedin : cutra.official@gmail.com